

EdgeVu Single Hung (H650)

Technical Data Sheet

Frame/Sash

- Architectural Grade 6063-T63 Aluminum
- Azon Thermal Break (Mainframe/Sash)
- SolidCore Thermal Barrier Technology
- 90° Corners Mainframe/Sash Corners
- 4-1/8" Overall Frame Depth
- Historically-Correct Beveled Exterior Sightlines
- 1-1/4" Pre-Punched Nail Fin

Weather stripping

- Bulb Seal Gaskets

Glazing

- Interior Glazing Stops
- Quanex Super Spacer
- 100% Silicone Wet Glaze
- Double/Triple Insulated Glass Options
- Annealed, Tempered, Laminated and Obscure Glass Options Available

Hardware

- Class V Commercial Balance
- Side Load Lower Sash
- Dual Auto-Locks at Lift Rail
- WOCD Available

Mulling Options

- Field Applied Structural Mulls

Grid Options

- Grids Between the Glass
- Simulated Divided Lites

Screen

- Flex Screen Standard

Paint

- 2604/2605 FGIA High Performance Powder Coatings
- 30 Standard Colors
- Custom Colors available

EdgeVu Single Hung (H650)		
NAFS Rating	AW-PG90-FW	
Design Pressure (P.S.F.)	90	
Air Infiltration at 25 MPH (cfm/ft ²)	<0.01	
Water Resistance	15	
U-Value (Based on Cardinal 366 Low-E/Argon Fill)	NA	
SHGC (Based on Cardinal 366 Low-E/Argon Fill)	NA	
Frame Sizing	Width	Height
Minimum	16"	30"
Maximum	72"	132"



Quaker Window Products
 504 U.S. Hwy 63 South
 Freeburg, MO 65035
 (800) 347-0438
www.quakerresidentialwindows.com

Discover More Here:



QTZ-EV-SNGLHNG-0324

EdgeVu (H655) Single Hung Window

Cross section details

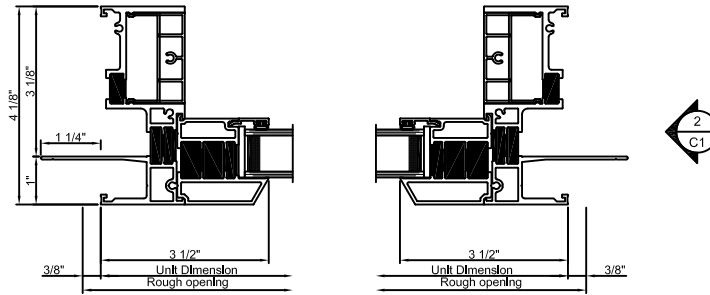

Window cut sections 1 : 4

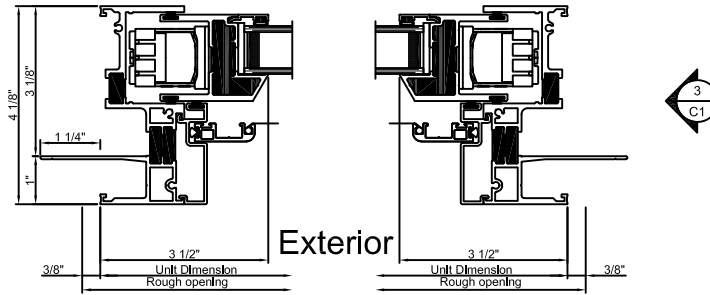

Exterior

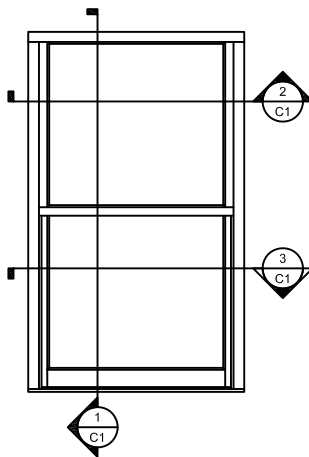

Window Elevation 3/8" = 1' 0"

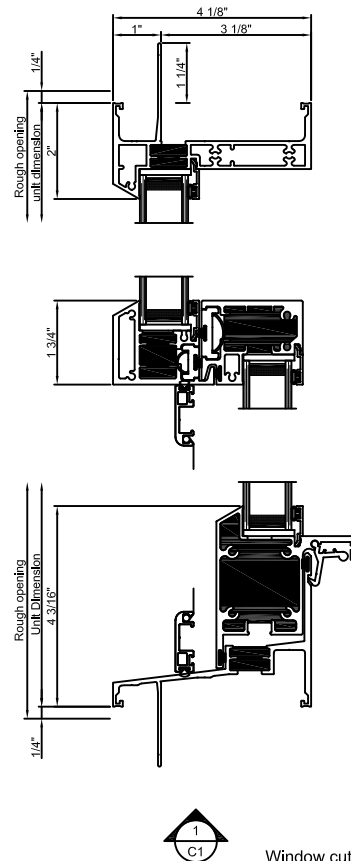

Window cut sections 1 : 4

Note: All dimensions are approximate. Quaker reserves the right to change specifications without notice.